

Regulator

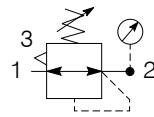

Symbols



Self relieving regulator with gauge

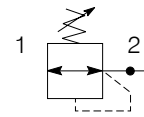

Non relieving regulator

- Integral 1/2 or 3/4 ports
- Secondary pressure ranges 8 & 16 bar
- Rolling diaphragm for extended life
- Secondary aspiration plus rolling diaphragm provides quick response and accurate pressure regulation.
- Optional tamperproof regulator, up to x 3 padlocks
- Relieving & Non-relieving types
- Low temperature -40°C as standard

Options:

P 3 X R A	□	□	□	□	□	□	N
BSPP (G) 1	1/2 4	Relieving B	Non rise - standard N	0 - 4 bar No Gauge L			
NPT * 9	3/4 6	Non-relieving N	Tamperproof - Lockable A	0 - 8 bar No Gauge N			
				0 - 16 bar No Gauge H			
				0 - 4 bar Gauge M			
				0 - 8 bar Gauge G			
				0 - 16 bar Gauge J			

* NPT ports on request
 1/2" size only

Port size	Description	Order Code	Flow dm ³ /s *	Max bar	Min temp °C	Max temp °C	Height mm	Width mm	Depth mm	Weight g
1/2	8 bar relieving	P3XRA14BNNN	122	16	-40	60	150	62	62	360
1/2	8 bar relieving + pressure gauge	P3XRA14BNGN	122	16	-10	60	150	62	95	410
3/4	8 bar relieving	P3XRA16BNNN	134	16	-40	60	150	62	62	360
3/4	8 bar relieving + pressure gauge	P3XRA16BNGN	134	16	-10	60	150	62	95	410
1/2	8 bar relieving with tamperproof facility	P3XRA14BANN	122	16	-40	60	158	62	62	360
1/2	8 bar relieving with tamperproof facility + pressure gauge	P3XRA14BAGN	122	16	-10	60	158	62	95	410
3/4	8 bar relieving with tamperproof facility	P3XRA16BANN	134	16	-40	60	158	62	62	360
3/4	8 bar relieving with tamperproof facility + pressure gauge	P3XRA16BAGN	134	16	-10	60	158	62	95	410

* flow with 10 bar inlet pressure, 6,3 bar set pressure and 1 bar pressure drop.
 Tamperproof regulator will require lock kit (on opposite page) to lock regulator.

Technical Information

Fluid:	Compressed air	
Maximum inlet pressure:	16 bar	
Temperature range*:	-40°C to +60°C	
Typical flow with 10 bar inlet pressure, 6.3 bar set pressure and 1 bar pressure drop:	1/2"	122 dm ³ /s
	3/4"	134 dm ³ /s
Gauge port (x 2):	1/4"	

* Air supply must be dry enough to avoid ice formation at temperatures below +2°C

Material Specification

Body:	High tech polymer
Bonnet:	High tech polymer
Regulator cover:	ABS
Control Knob:	Polyamide
Valve:	Brass / Nitrile
Seals:	Nitrile NBR
Screws:	Stainless steel

Dimensions (mm)

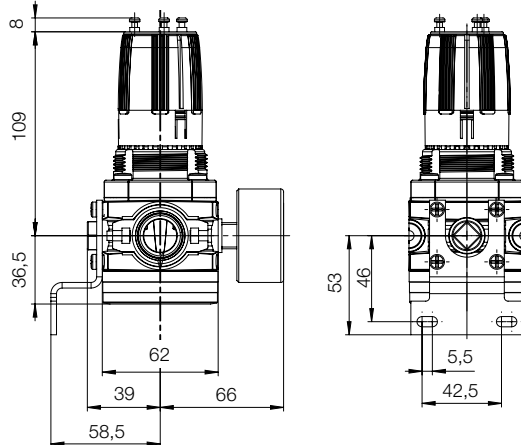

Service kits

Description	Order code
Wall bracket - Stainless steel	P3XKA00MW
Panel mounting nut	P3XKA00MM
Key lock	P3XKA00AS
Diaphragm kit (relieving type)	P3XKA00RR
Diaphragm kit (non-relieving type)	P3XKA00RN

Lockable Tamperproof Kit (up to x 3 padlocks)

This facilitates the tamperproofing of the Regulator and Filter-Regulator units. (On request)



Order code

1 Padlock each

P3XKA00AS

Flow characteristics

Regulation characteristics: (1/2)

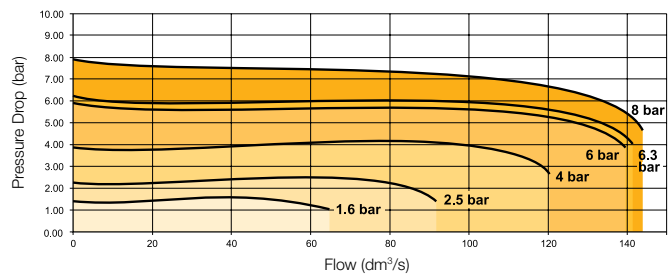

Regulation characteristics: (3/4)

