



Worthington
Creyssensac



AIR COMPRESSORS **ROLLAIR®**

550-750-1000-1500

KEEPING UP WITH THE TIMES

The modern ROLLAIR® is the result of the new construction philosophy based on several years of continuous product development.

Assisted by advanced technologies and sophisticated equipment, engineering and technical staff work together closely on a daily basis to control the efficiency and quality of the products.

Our aim is simply to produce a compressor that sets the standard for the compressed air industry.



RELIABILITY AND COMPACT DESIGN

Our ambition at Worthington Creyssensac is to offer a compressed air solution that is guaranteed to meet customer satisfaction.

Each product is built according to standards and is carefully controlled during every phase of the process by skilled staff to ensure that the specific quality and functional tests are passed.

- **Reliability** production and testing techniques ensure product reliability.
- **Compact design** small base for simple installation.
- **Ready to use** simply connect it to the power mains and pneumatic line.
- **Easy maintenance** quick access to essential components = reduced maintenance costs.

A COMPLETE RANGE



ROLLAIR® T



ROLLAIR® T 270 I.
ROLLAIR® T 500 I.



ROLLAIR®



ROLLAIR® 270 I.
ROLLAIR® 500 I.

ROLLAIR® 550 - 750 - 1000 - 1500: Simplicity and Reliability

Encapsulated internal air filter

- ① One of the most important factors as far as performance and the service life of the air end are concerned is the inlet air treatment. For this purpose, the ROLLAIR® 550 - 1500 range uses an inlet filter with particle removal down to 2 µm. A large element surface ensures a long service life and minimal pressure drop. To improve the quality of the inlet air, the following options are available:
- High-efficiency external air intake filtration.
 - High-efficiency external pre-filtration panel.

Integrated refrigerant dryer

- ② In the integrated dryer version, the compressed air is perfectly and totally dehumidified thanks to a refrigerant dryer

Oil filter and air/oil separator

- ③ The oil separation system ensures that the compressed air contains less than 3 ppm of oil. Easy, quick and economical to maintain: only two panels need to be removed.

Electric motor

- ④ High-efficiency motor (Eff. 1 for ROLLAIR® 1000 – 1500), class F with IP 55 protection.

Soundproofed canopy

- ⑤ Soundproofed steel panels painted with epoxy powder paint.

INFOLOGIC® electronic controller

- ⑥ A simple and reliable control system.

Air/oil cooling

- ⑦ A combined air/air and air/oil oversized aluminum cooler with a large surface area for maximum cooling efficiency. This ensures low delivery air temperature and correct lubricating oil temperature, improving the service life and performance of the components.

Vertical oil vessel

- ⑧ An innovative centrifugal system for mechanical pre-separation. Oil level is visible from the outside for rapid and immediate control.

Water separator option (comes as standard on ROLLAIR® T)

- ⑨ Located before the dryer, the water separator provides initial water separation from the compressed air. This is added benefit to the dryer and eventually in the compressed air in your network.

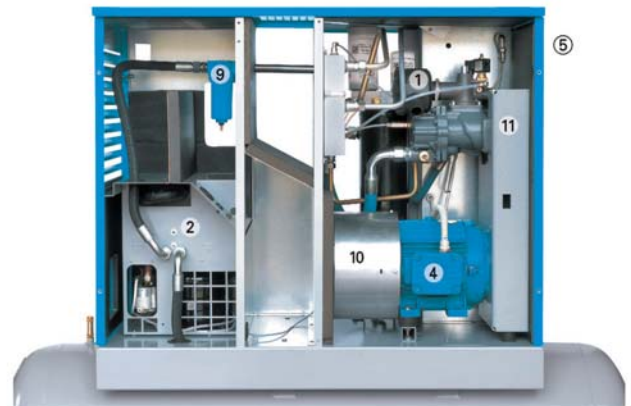

Fan

- ⑩ Low-noise fan with polypropylene airfoil profile blades. Fixed on the shaft motor, it conveys the air flow directly around the motor and through the cooler.

Pulley and belt assembly

- ⑪ The transmission has been built in a way that allows guided alignment of the belts and pulleys.

NEW COOLING EFFICIENCY

A careful analysis of the air flow and the correct positioning of the main components ensure low internal temperature and an optimal temperature at the air outlet.

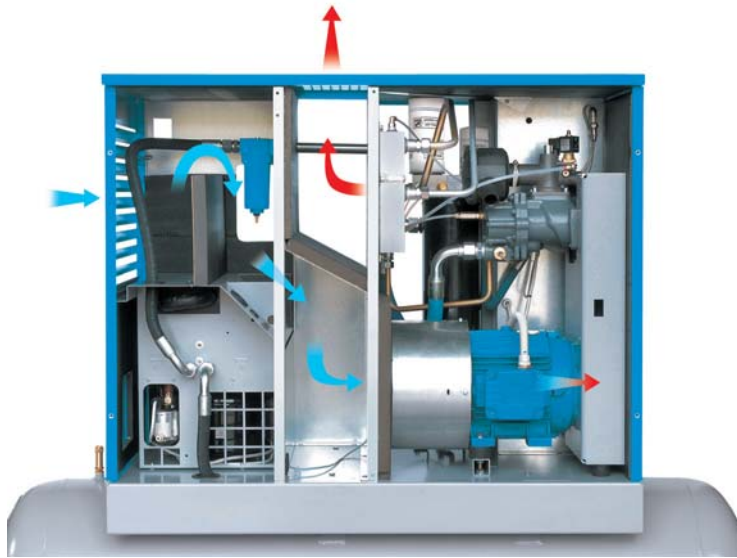

All of this leads to:

- A low working temperature.
- An increase in performance.
- Increased service life of the components.
- Less maintenance.

ROLLAIR® T: INTEGRATED REFRIGERANT DRYER

An integrated refrigerant dryer has been developed to supply dry compressed air for your production process, with minimum power requirement, low pressure drop, minimal installation cost and minimum floor space requirement. In the event of dryer failure, a by-pass (optional) allows compressed air production to continue.

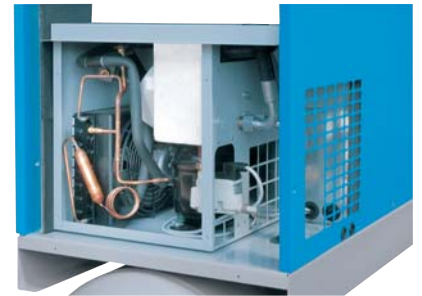

An intelligent, automatic condensate discharger is a standard component in the dryer.

Advantages:

- Only discharges water, NOT compressed air.
- Silent operation, no acoustic impact.



EASY MAINTENANCE

Only two panels need to be removed to access the standard maintenance components. The oil level is visible from the outside for rapid and immediate control. To replace or tension the belt, only the side panel needs to be removed.



The INFOLOGIC® electronic controller is fitted as standard on all ROLLAIR® 550-1500 fixed-speed compressors. With its icon display and user friendly panel, you can obtain useful visual control and diagnostic information.



A backlit 4-digit and 7-segment icon display for operational, safety and service information.

3 LEDs

- Auto Run.
- Error or Warning.
- Power on.

Standard INFOLOGIC® functions

- Pressure display.
- Temperature and dew point display.
- High and low temperature default.
- Motor start-up limit.
- Remote default.
- Remote stop/start.
- Programmable auto-restart.
- CAN communication port.
- Slave in MULTILOGIC® network.

ROLLAIR® V - HIGH TECHNOLOGY

Inverter is an intelligent system that maintains the pressure constant at the outlet by regulating the motor's rotation speed according to the air demand.

ROLLAIR® V are EMC certified which guarantees no electromagnetic interference.



ENERGY SAVING

V benefits:

- Energy consumption is based on air demand.
- No waste energy during unload time.
- Constant pressure within +/- 0.1 bar.
- Ramped motor start-up avoids the electric motor peaking.

Result

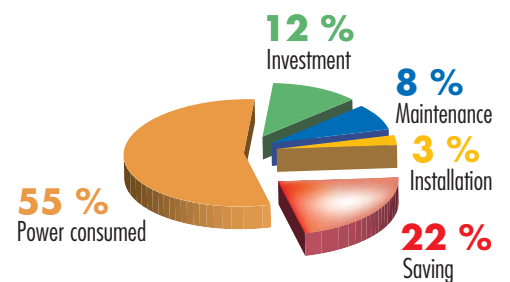

HIGH EFFICIENCY 1 MOTOR:

Soft startup

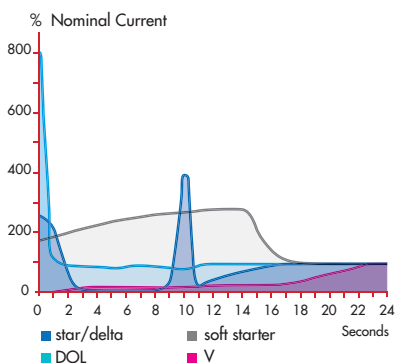

Motors in Eff. 1 have constructive characteristics and materials that have been specially developed and help reduce energy consumption by up to 20%, increasing the service life of the motor.

LOW NOISE LEVEL = ENVIRONMENTALLY FRIENDLY

Worthington Creyssensac cares about the environment, and has increased its research efforts to reduce noise level without compromising efficiency and reliability.

The sound-absorbent panels, anti-vibration pads, deflectors, along with the correct positioning of the internal components, reduce noise levels considerably.

This allows the units to be installed near the work place, thus reducing installation costs.

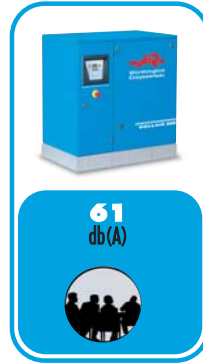

COMPACT INSTALLATION

The compact installation means:

- Low installation costs (dryer and air receiver are factory mounted).
- No leakage risk.
- Smaller base.
- Piping designed for minimal pressure drop.



COMPLEX INSTALLATION

With a complex installation:

- More space is needed.
- Installation costs are higher.



OPTIONS

Options activated by service staff:

- Remote load/unload: two free contacts in the cubicle.
- Remote start/stop: two free contacts in the cubicle.
- Remote general fault: two free contacts in the cubicle.
- Auto restart: standard (to be activated).

Factory-fitted options:

- Water separator: standard on T and VT unit.
- Automatic draining for machines with water separator.
- Bypass dryer.
- High-efficiency air intake filtration.
- High-efficiency pre-filtration panel.
- AIRLOGIC® controller as a retrofit kit.

Technical Data

FIX SPEED VERSION	Working pressure*	Free air delivery** at ref. conditions		Motor power		Noise level***	Cooling air volume	Weight Kg				
	bar	m ³ /h	cfm	kW	hp	dB(A)	m ³ /h	Standard	270 l.	500 l.	Extra weight on T	
ROLLAIR® 550												
A	8	36	21,2	4	5,5	59	2200	185	60	160	35	
B	10	30	17,7	4	5,5	59						
ROLLAIR® 750												
A	8	50	29,4	5,5	7,5	60	2200	195	60	160	35	
B	10	41,5	24,4	5,5	7,5	60						
C	13	30,2	17,8	5,5	7,5	60						
ROLLAIR® 1000												
A	8	70	41,2	7,5	10	61	2200	215	60	160	35	
B	10	59,8	35,2	7,5	10	61						
C	13	47,9	28,2	7,5	10	61						
ROLLAIR® 1500												
A	8	102	60,0	11	15	61	2200	256	60	160	35	
B	10	86	50,6	11	15	61						
C	13	71,7	42,2	11	15	61						

* 0,25 bar less on T version

** as per ISO 1217 : 1996

*** as per CAGI PNEUROP PN8NCT2

VARIABLE SPEED VERSION	FAD min.		Free air delivery at reference conditions* FAD max.					Motor power		Noise level**	Cooling air volume	Weight Kg						
	m ³ /h	cfm	5 bar		7 bar		9,5 bar		12,5 bar		dB(A)	m ³ /h	Standard	270 l.	500 l.	Extra weight on T		
			m ³ /h	cfm	m ³ /h	cfm	m ³ /h	cfm	m ³ /h	cfm							kW	hp
ROLLAIR® 1500																		
V	15,5	9	103	60,6	101	59,4	93,4	55	82,9	48,8	11	15	61	2200	271	60	160	35

* as per ISO 1217 : 1996

** as per CAGI PNEUROP PN8NCT2

Dimensions

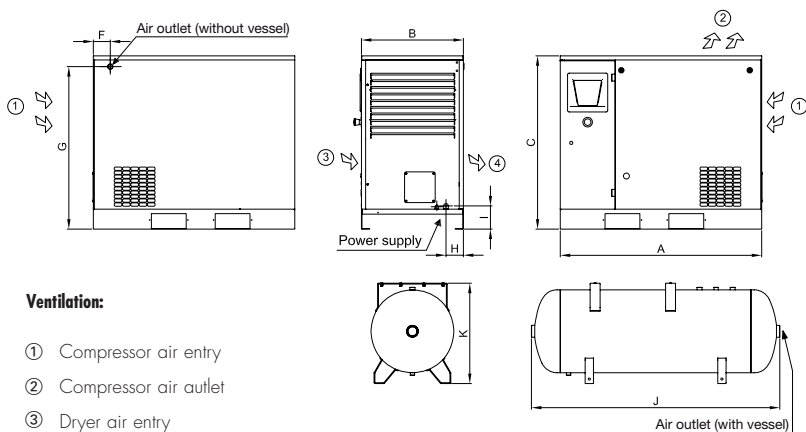

Ventilation:

- ① Compressor air entry
- ② Compressor air outlet
- ③ Dryer air entry
- ④ Dryer air outlet

ROLLAIR® 550-750-1000-1500

Ref. marks	Weight Kg	
A with dryer	1215	
A without dryer	965	
B	662	
C	1045	
Air outlet		
F	102	
G	980	
Power supply		
H	105	
I	140	
Air receiver		
	270 litres	500 litres
J	1530	1935
K	486	620

Dimension in mm

SHARING OUR VALUES



PARTNERSHIPS

Close working partnerships form the foundation of our corporate culture. This identity has grown from our strength in developing long term partnerships with our distribution and sales networks that have local knowledge and experience to provide a total compressed air solution service, tailored specifically to our customers' requirements.

Our business approach has earned us a reputation of trust and loyalty committed to achieving success through partnership.

COMPETENCE

Personnel skill development is a vital part of our success: by a continuous improvement process we improve the ability of our personnel to maintain and improve the service to our customers.

We carry this process through to our partner distributors to ensure that we create a motivated and enthusiastic team working together for the benefit of our customers.

EVOLUTION

Our strategy in product and service development is based on continuous improvement of our products and services in order to meet the requirement of the market and our customers. Continued investment in the design of new products and the use of innovating technologies keep our compressed air solutions amongst the most competitive in the industry. This is our mission to guarantee the satisfaction and trust of our customers.

UK

Worthington Creyssensac
Air Compressor Products Ltd.
Unit 11, Ravenhurst Court
Risley Road
Birchwood Warrington
Cheshire WA3 6PN
Phone: 01925 817803
Fax: 01925 850186

Export

Worthington Creyssensac
Zone Industrielle 4 rue Émile Zola
B.P. 80419 60114 Méru France
Tél: 33(0)3 44 52 67 31
Fax: 33(0)3 44 52 67 35
wce.info@airwco.com



YOUR DISTRIBUTOR



www.airwco.com